

PRORIL

50Hz

Rugged, reliable and cost effective, the Titan series pumps deliver excellent performance and serve a wide range of tough dewatering applications like mines, construction site, rental applications and other demanding industries.

Dewatering Pump

TITAN 4110/6110

Heavy Duty Dewatering Pump



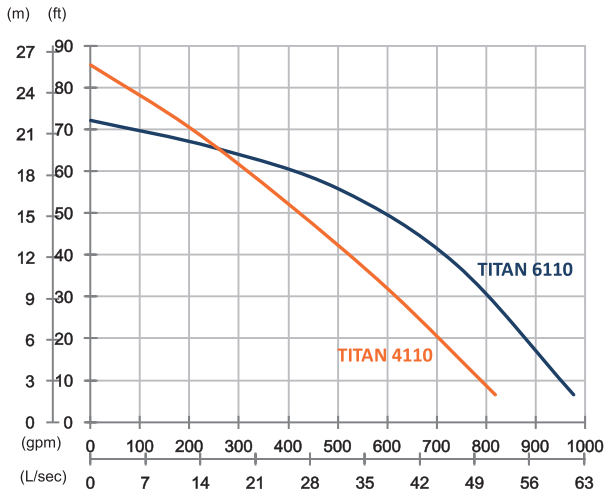

	TITAN 4110	TITAN 6110
OUTPUT	11 kW (15 HP)	11 kW (15 HP)
OUTLET	4" (100 mm)	6" (150 mm)
SOLID PASSAGE	25 mm	35 mm
Weight	195 kg	196 kg
HEAD	Rated: 16 m Max: 26 m	Rated: 17 m Max: 22 m
FLOW	Rated: 25 L/s Max: 51.6 L/s	Rated: 31.7 L/s Max: 61.6 L/s

Pump Type		Electric Submersible Pumps
Motor	Phase	3-Phase
	Type	Induction Motor
	Poles	4 Pole (1450 rpm)
	Insulation	Class F
	Protector	Circle Thermal Protector
	Starter	D.O.L.
Lubricant		Food Grade (ISO VG32)
Specs.	Impeller Type	Opened
	Shaft Seal	Double Mechanical Seal
		Silicon Carbide VS Ceramic/Carbon
	Bearings	C3 Shielded ball bearings
	Cable	H07BQ-F
10 m or longer upon request		
Materials	Pump Casing	Ductile Iron
	Impeller	Chromium Iron
	Motor Frame	Gray Iron
	Motor Shaft	Stainless Steel
	Strainer	Carbon Steel
Max. Liquid Temperature		40°C (104°F)
Max. Submersion Depth		20 m (66 ft)
pH Range		pH 5 - pH 8

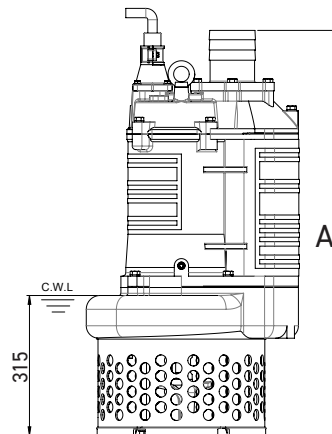
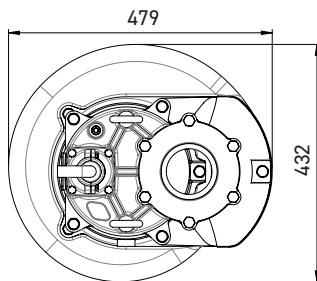

unit : mm

C.W.L : Continuous running water level

	A
TITAN 4110	910
TITAN 6110	922